

lasting strength
with fibre-cement

nutec
ROOFING AND CLADDING SOLUTIONS

Manufactured by
EVERITE
Established in 1941

CEILING BOARDS

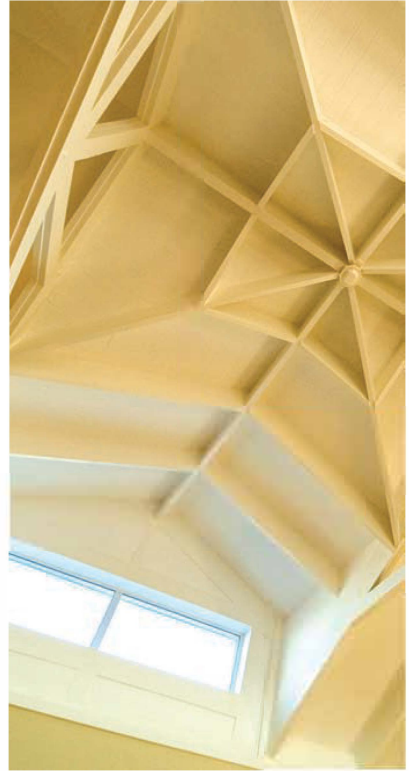
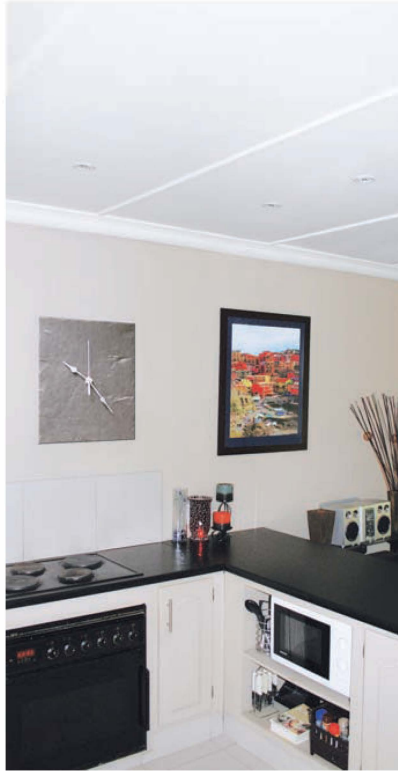



CONTENTS

About Everite and Nutec	2
Nutec Ceiling Board Features	4
Safety, Handling and Storage	5
General Design Criteria	6
Nutec Ceiling Boards Product Range	7
Nutec Ceiling Board Fixing Accessories	8
Installation Procedures	9
Nucornice Product Range	15
Nucornice Installation Procedures	16
Nucornice Adhesive	18
Mechanical and Physical Properties	20
Everite National Offices and Contact Details	24

Catalogue Information

The information contained in this catalogue serves as a general guide only and should not be accepted as the standard for all construction. EVERITE can assist in designs of a special nature, however, architects, engineers and specifiers must finally approve the acceptability in terms of the design and construction criteria, as well as other implications.

About Everite and Nutec

■ Everite Building Products

Everite Building Products, has been associated with the South African building industry since 1941. Producing a wide range of materials that satisfy the needs of the commercial, industrial and residential market sectors, Everite is renowned for its comprehensive range of Nutec Roofing and Cladding Solutions and includes fibre-cement roofing, cladding, ceilings and building columns amongst others.

Nutec fibre-cement high performance properties and added benefits include: the use of safe renewable fibres; considerable tensile strength with enhanced dynamic load bearing properties; excellent thermal properties; water and wind resistance; hail resistance; fire resistance and resistance to fungus, rodents and acid.

A programme of quality assurance in accordance with the requirements of the International Standards Organisation (ISO 9001:2015) is entrenched in Everite's process and management systems. Quality of all products is continuously monitored as specified by the South African National Standards and recognised international bodies.

Everite's 54 hectare manufacturing facility near Johannesburg is well located and has immediate access to all major road and rail links to national destinations and major ports. The company has branches located at major centres throughout South Africa. Nutec products are distributed through leading stockists countrywide and an established export market further endorses the international acceptance of the Nutec Roofing and Cladding Solutions range of products.

■ Nutec

Nutec is the registered name for products manufactured without asbestos as a raw material. Nutec fibre cement products are manufactured using a mixture of cellulose fibre, cement, silica and water.

Through ongoing research and development, Everite Building Products are committed to provide product of world-class quality.

Accordingly, the Nutec product range is continuously reviewed not only in the interests of the end-user and superior product performance, but also with respect to its impact on the environment. Everite Building Products has over the years established a reputation for producing a variety of outstanding quality products which have been used in a wide range of external and internal applications.

Environmental benefits of Nutec Fibre Cement

- Environmental costs incurred by using fibre cement are measurably less than for other building materials. (Low embodied energy per m²).
- Requires less energy in assembly and construction than all other wall materials except timber.
- Low energy consumption in transportation and installation.
- Environmental costs relating to ozone layer depletion, carcinogenic substances and solid waste emissions are almost negligible.
- Low environmental impact in relation to ozone layer depletion, carcinogenic substances, and solid waste emissions.
- No pesticides are involved in the manufacture or use of fibre cement.

The benefits of Nutec Fibre Cement

- The use of safe fibres.
- Considerable tensile strength with enhanced dynamic load bearing properties.
- Cost competitive.
- Excellent thermal properties.
- Water tight and wind resistant.
- Hail resistant.
- Fire-resistant.
- Fungus and rodent resistant.
- Acid resistant.
- Complies with SABS ISO 9933.
- ISO 9001 : 2015 Quality Management System.

The environmental benefits in the manufacturing process of Nutec Fibre Cement

- Recycling the water used in production many times.
- Recycling solid wastes.
- Using sustainable raw materials in production.

Embodied Energy – Definition

Embodied energy is the energy consumed by all of the processes associated with the production of a building, from the mining and processing of natural resources to manufacturing, transport and product delivery. Embodied energy does not include the operation and disposal of the building material. This would be considered in a life cycle approach. Embodied energy is the 'upstream' or 'front-end' component of the lifecycle impact of a home. Fibre cement is one of the most energy efficient materials on the market and it has one of the lowest embodied energy contents per square metre of cover of any building product.

NUTEC CEILING BOARD FEATURES

Nutec Ceiling Boards

The application of Nutec Ceiling Boards goes beyond the regular flat look. Raking or cathedral style ceilings installed between roof rafters creates a luxurious and spacious look to any room at an affordable price. Nutec Ceiling Boards are available in a plain or textured timber-grain like finish that simulates the look of real timber.

Nutec plain and textured ceiling boards are extensively used as nail-up ceilings and as an all-purpose building board for other interior and exterior applications. Not only are these products ideal for general use indoors, but because these products are not affected by moisture and are therefore ideal for use in damp areas such as kitchens, bathrooms and verandas, as well as for under eaves linings.

■ Features

- Nutec Ceiling Boards exhibit all the inherent features of Nutec fibre-cement.
- An economical all-purpose ceiling board, unaffected by moisture and ideal for internal use in almost any conceivable application.
- Nutec Ceiling Boards are supplied in their natural colour and will accept all water-based paints without pre-treatment.
- Nutec Ceiling Boards are non-combustible and will therefore inhibit the spread of fire. They provide perfect protection against flying sparks.
- The material will not rot and cannot be damaged by termites and rodents.
- Resistant to corrosion.
- All plain ceiling boards are manufactured and tested in accordance with the South African Bureau of Standards Specification SANS 9001:2015 (ISO 9001). The product also carries an SABS Mark under specification SABS 803.
- Manufactured to the highest internal quality standards. Compliance is ensured by strict quality assurance programmes in the production process as well as stringent testing in our laboratory.

Safety, Handling and Storage Instructions

Safety

Safety rules as per current legislation and work practices as described in General Installation Guidelines must be observed when working with the product.

Handling

Nutec Ceiling Boards are cement-based and may be damaged under excessively high shock loads. Reasonable care should therefore be taken to ensure that the products are not dropped or subjected to rough handling. Nutec Ceiling Boards should not be exposed to the elements and under cover storage is recommended.

Storage

A smooth level under cover area should therefore be made available where the boards can be stacked safely. The boards should be stacked clear off the ground on suitable timber supports at maximum 400 mm centres and the edges and corners protected against possible damage.

Where under cover storage is not available, the stacked product should be covered to avoid it becoming soaked with water. Soaked boards will be difficult to handle and should be allowed to dry out before use.

GENERAL DESIGN CRITERIA

General Design Criteria

Supporting Structure

To ensure a high standard of finish, it is essential that the supporting structure is accurate and sound. Warped, twisted or poor quality battens will reflect in the finished surface of the ceiling and for best results selected structural grade timber should be used. When a perfectly flat ceiling is required and lighting conditions are such that the slightest unevenness would be accentuated, the branderling should be accurately sized and the spacing decreased.

Soffit Applications

For soffit applications areas where high wind pressures prevail, an architect or engineer should be consulted for particular fixing and framing conditions.

Condensation

Condensation normally has no effect on Nutec Ceiling Boards, but it is nevertheless recommended that the space between the ceiling and the roof is adequately ventilated.

Fixing Accessories

A specially designed range of fixing accessories such as nails, H-profile strips and cornices are obtainable from EVERITE, full details are scheduled under Fixing Accessories.

Site Service

Site service personnel are available on request, to provide assistance on recommended storage, handling and installation of Everite's products.

Standard Branderling for Different Truss Spacings

The size of branderling used to construct the supporting framework for the Nutec Ceiling Boards is dependent on the spacing of trusses or rafters. *Refer to Table 1.*

Storage

Nutec Ceiling Boards must be stored indoors.

NUTEC CEILING BOARDS PRODUCT RANGE

Product Range

■ Nutec Ceiling Boards Product Range, Dimensions and Properties

Plain Boards

Product No.	Nominal thickness mm	Size mm	Average Mass (kg)
060-403	4	2 400 x 900	13,0
060-405	4	3 000 x 900	16,0
060-406	4	3 300 x 900	18,0
060-407	4	3 600 x 900	20,0
060-410	4	2 400 x 1 200	17,0
060-412	4	3 000 x 1 200	22,0
060-413	4	3 300 x 1 200	24,0
060-414	4	3 600 x 1 200	26,0
060-610	6	2 400 x 900	18,0
060-612	6	3 000 x 900	23,0
060-614	6	3 600 x 900	27,0
060-617	6	2 400 x 1 200	25,0
060-619	6	3 000 x 1 200	31,0
060-621	6	3 600 x 1 200	37,0

Selection guide for Nutec Ceiling Boards

Ceiling Range	Thickness mm	Width mm	Length mm	Product Application	
				Nail-up Ceilings & Soffits	Exposed Beams
Nutec (plain)	4 6	900	2 400 – 3 600 mm 300 mm increments	✓	✓
Nutec (plain)	4 6	1 200	2 400 – 3 600 mm 300 mm increments	✓	✓

NUTEC CEILING BOARD FIXING ACCESSORIES

Nutec Ceiling Board Fixing Accessories

Product No.	Description	Size mm	Length mm	Average Mass kg
685-080 685-081 685-084 685-085	H-profile Steel jointing strip	4 4 6 6	3 600 4 800 3 600 4 800	0,73 0,98 0,73 0,98
685-283 685-285 685-289 690-038	H-profile P.V.C. jointing strip white	4 4 4 6	3 000 3 600 4 800 3 600	0,30 0,36 0,50 0,001
605-632	Fasteners Galvanised serrated ceiling nails	2,5	32	750/kg app.
605-756 605-730 605-736	Cornice Plain Cove Cornice Plain (Non Paper Covering) Nu-Doric Nu-Doric	75 mm 75 mm 75 mm	3 000 3 000 3 600	0,10 0,12 0,14
605-750 605-751 605-754 605-755	Cornice Profiled Nu-Doric Nu-Doric Nu-Corinthian Nu-Corinthian	127 mm 127 mm 127 mm 127 mm	3 000 3 600 3 000 3 600	0,14 0,15 0,14 0,15
605-749 605-803 605-804	Nucornice Adhesive Tube Tub Bucket	310 ml 2 L 5 L		0.45 kg 3.0 kg 7.6 kg

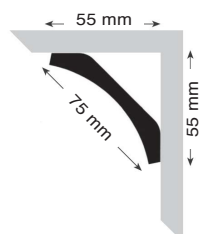

Nu-Doric Plain 75

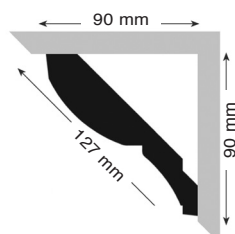

Nu-Doric 127

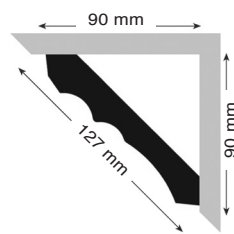

Nu-Corinthian 127

General Installation Guidelines

The following basic safety rules and work practices should be observed when working with the product.

- Although Nutec Ceiling Boards are manufactured without asbestos as a raw material, it is nevertheless recommended that tools which do not create excessive dust are used when working with the product.

Ordinary carpenters' tools can be used effectively.

- For straight cutting of either 4 mm or 6 mm Nutec Ceiling Boards, a scribe or any other sharp object is all that is required to scribe the surface of the board. The board will break on this line if held firmly on a flat surface with a straight edge and the surplus board snapped off [Refer Fig. 1 and Fig. 2](#).

Fig 1 : Scribing the Board

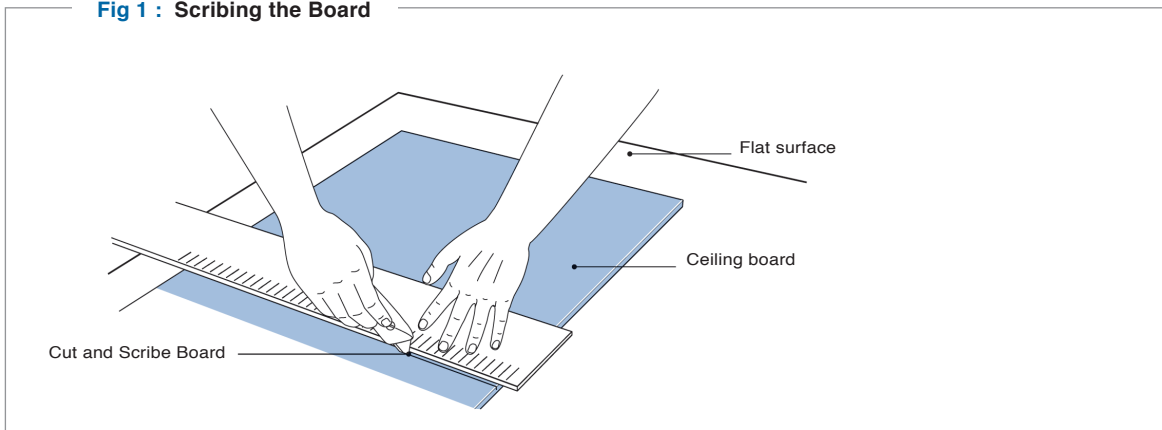
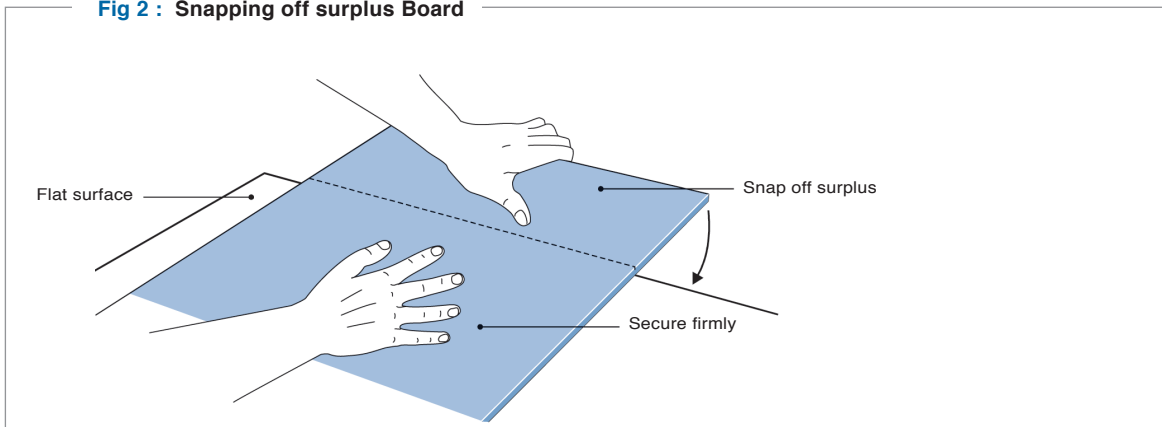

Fig 2 : Snapping off surplus Board



Installation Procedures for Standard Nutec Ceilings

TABLE 1

Standard Brandering/Truss spacing

Truss or Rafter Spacing	Branderling Size Required
1 050 (maximum)	38 mm x 38 mm
1 500 (maximum)	38 mm x 50 mm on edge

NB: Specially designed brandering is required for truss or rafter spacings in excess of those shown in this table.

Branderling Requirements

The spacing of brandering shown in [Table 2](#) is based on practical tests carried out for the various thicknesses of ceiling boards.

Cross brandering is necessary at the joints and when cornices are to be fixed at right angles to the brandering.

TABLE 2

Spacing of Branderling for Standard Nutec Ceiling Boards STEP 1

Board Thickness	Maximum Branderling Centres
4 mm	450 mm
6 mm	600 mm

Using H-Profile Jointing Strips

■ Step 1

Installing supporting brandering. *Refer Fig. 3*

- Starting at one end of the room and at right angles to the trusses, nail a length of brandering to the tie beams of the rafters 25 mm away from the wall. Nail another length of brandering to the tie beams on the opposite end of the room, 25 mm away from the wall.
- Bearing in mind the maximum spacing required, *refer Table 2*. Commence at the first piece of brandering erected and mark the spacings for the brandering on the tie beam next to the one wall. Repeat this on the tie beam at the opposite side of the room. With the aid of a chalk line mark the remaining tie beams accordingly. Skew nail brandering to the tie beams on the lines marked.
- To provide for fixing the cornice, fix short pieces of brandering 25 mm away from the walls at right angles to and between the brandering already installed.
- Install supporting timber where light fittings are to be suspended from the ceiling.

Installation Procedures for Standard Nutec Ceilings. (Cont.)

Fig 3 : Installing Supporting Brandering

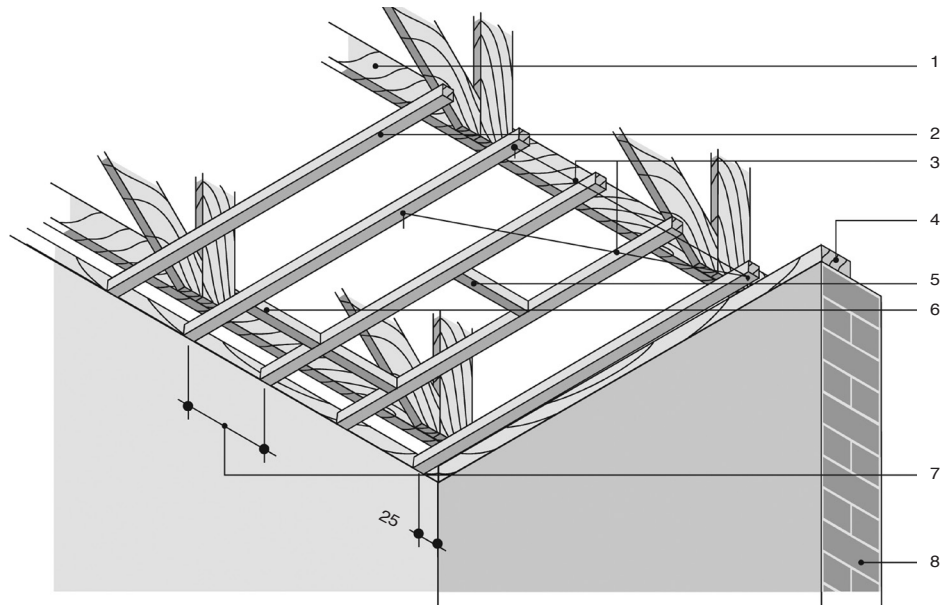

All measurements in mm

KEY	
1. Tie beams of truss. Maximum spacing as per Table 1	5. Brandering as support for light fitting
2. Brandering	6. Cross brandering
3. Fish lines for levelling of brandering	7. Brandering spacing as per Table 2
4. Wall plate	8. Wall

■ Step 2

Levelling of the brandering. Refer Fig. 3 and Fig. 4

- To check the level of the brandering, span a fish line across the room in various positions.
- Use wooden wedges to level where necessary.

Fig 4 : Levelling of the Brandering by Wedging

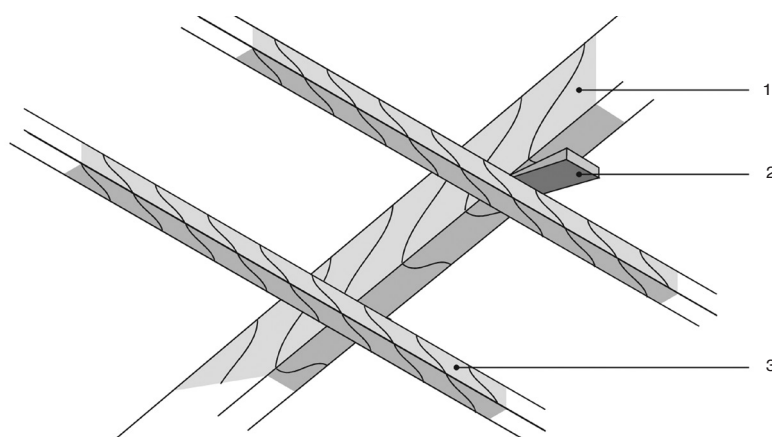

KEY	
1. Tie beam of truss	
2. Timber wedge	
3. Brandering	

INSTALLATION PROCEDURE

Installation Procedures for Standard Nutec Ceilings. (Cont.)

■ Step 3

Installing Nutec Ceiling Boards. Refer Fig. 5

- Measure the length and width of the room to establish the number of full boards required. Space the boards so that the standard width boards are fixed from the centre, finishing off with equal cut boards at each side of the room.
- Starting from the middle, place the ceiling boards at right angles across the branding on the position previously established and nail in place with 32 x 2,5 mm serrated ceiling nails. The nails should be placed at 150 mm centres and not closer than 12 mm from any edge of the board.
- Push an H-profile jointing strip onto the long edge of the board. Fit the next board into the H-profile strip and fix that board.
- Fit H-profile cross sections cut to size onto the short edges of the board.
- Repeat this procedure until the ceiling is complete.

NB: If more than one board is required for the length of the room, the best effect is achieved with staggered joints.

Fig 5 : Installing Nutec Ceiling Boards

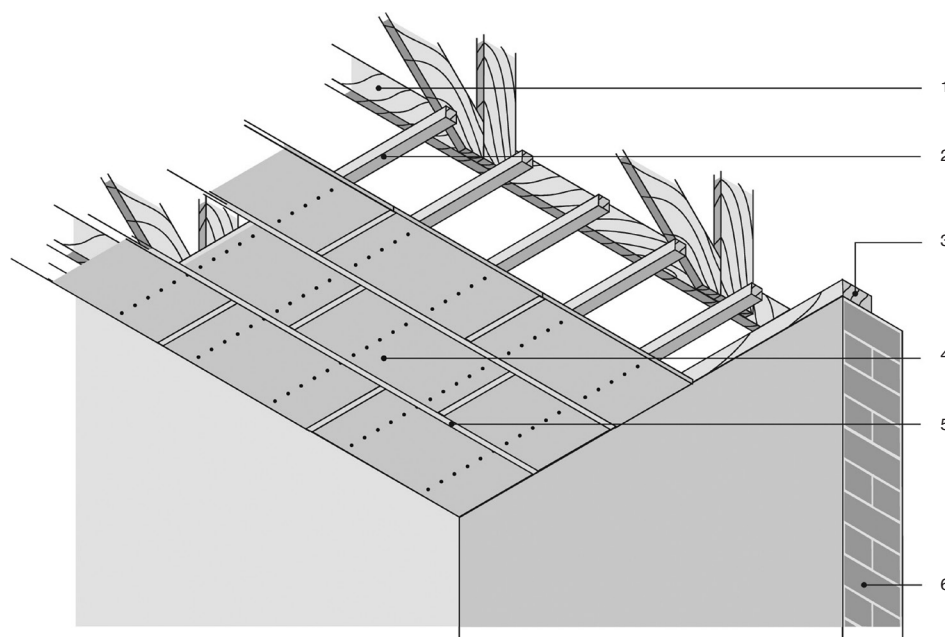

KEY	
1 Tie Beam	4 Nutec Ceiling Board
2 Branding	5 H-profile jointing strip
3 Wallplate	6 Wall

Installation Procedure for Exposed Beam Method

In this application the beams perform a dual function, that of a load bearing structure as well as a decorative feature. The Nutec Ceiling Boards, plain or textured are fixed on top of the beams or between them.

General Guidelines

For fixing on top of the beams, the following steps should be followed:

- The spacing of the beams must be at 400 mm centres or 600 mm centres for 4 mm or 6 mm Nutec Ceiling Boards respectively.
- The spanning capabilities of the board can be increased by nailing brading on the reverse side of the board at the appropriate centres before installation.
- The beams which are the feature of this application must naturally be clean and straight, as well as properly aligned. Twisted or warped beams will negatively influence the final ceiling.

■ Step 1

Installing the board. *Refer Fig. 6(A)*

- Fix boards on top of and parallel to the beams thus reducing the number of visible joints.
- For cross joints use H-profile jointing strips cut to size.

■ Step 2

Adapting the roof structure. *Refer Fig. 6(B)*.

- Fix counter battens on top of the ceiling board directly above the beams.

Take care not to damage the ceiling board when nailing on the battens.

- Fix waterproofing membrane over counter battens, allowing it to sag onto the ceiling board between the counter battens.
- Fix battens or purlins for roofing material over waterproofing membrane through counter battens into the rafter.

Pre-drilling of pilot holes is recommended to reduce the possibility of damaging the ceiling board.

Installation Procedure for Exposed Beam Method. (Cont.)

Fig 6 : Roof/Ceiling Structure

Fig 6 (A) Fixing Ceilings Over Beams

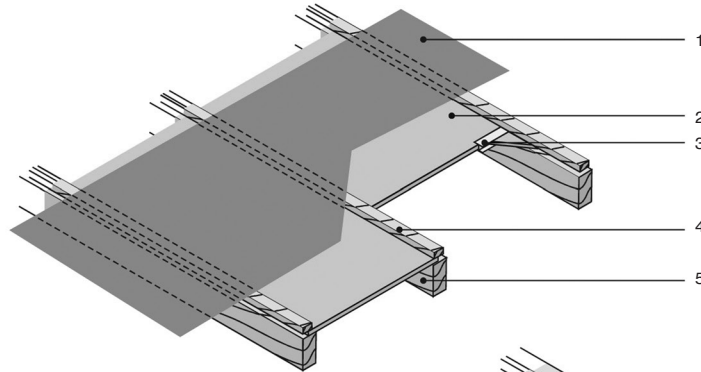
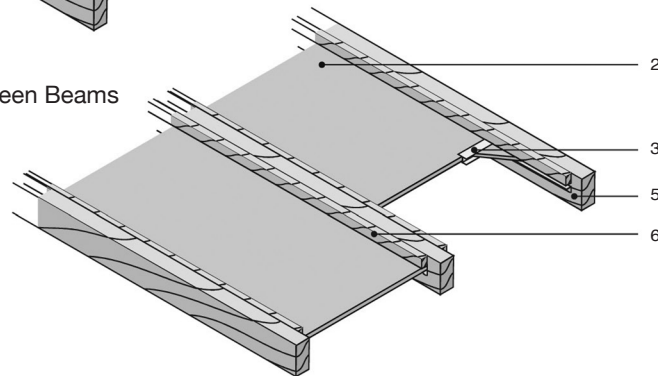

Fig 6 (B) Fixing Ceilings In Between Beams



KEY

1	Waterproofing membrane
2	Nutec Ceiling Board
3	H-profile jointing strip
4	Counter batten
5	Timber beam
6	Branding

- NB:**
- In cases where the roof structure and roof are already in position, it is necessary to install supporting timber for the ceiling. Where the spacing of the beams is within the spanning capabilities of the ceiling board, refer Table 2, it is only necessary to install a strip of supporting brandering on both sides of the beams to which the ceiling can be nailed, refer [Fig 6 \(B\)](#).
 - A timber quadrant can be used to finish off the board edges where they join the beams and the H-profile jointing strip cut to size can be used on cross joints.
 - Where the beam spacing exceeds 600 mm a supporting grid must be installed according to the directions under Step 1.

Nucornice Product Range, Dimensions and Properties

■ Nucornice

The product

Nucornice is a paper covered polystyrene core cove cornice. It is designed for use as a decorative fixing cornice at the angle where wall and ceiling meet.

Nucornice is lightweight, durable, easy to handle and suitable for all dwellings.

Specifications

1. Width: 75 mm & 127 mm
2. Lengths: 3,0 m and 3,6 m
3. Mass: 40 g per metre

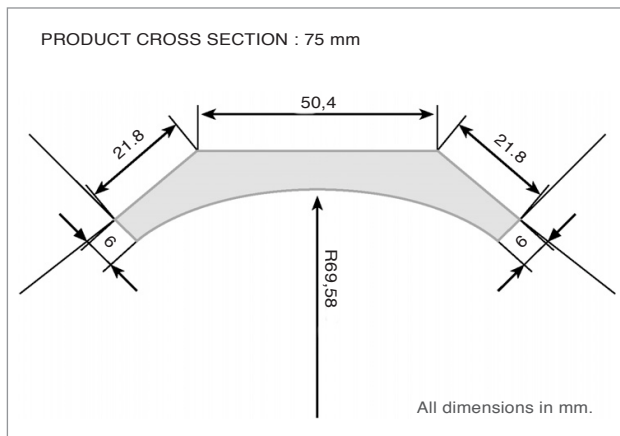

Nucornice performance

Nucornice will last as long as the life of a building/house under normal conditions.

Nucornice can be used to seal air passage ways around ceilings and will assist thermal insulation performance between rooms.

Nucornice Installation Guide

■ Mitres

1. External Angles

- (a) Left hand
- (b) Right hand

2. Internal Angles

- (c) Left hand
- (d) Right hand

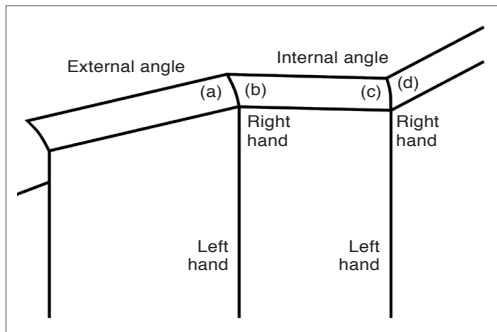

■ Cutting Mitres

In order to cut a left hand corner mitre, the mitre must be positioned to the left of the length of cornice and line up the measured mark with the opposite mitre block slot (depending on whether the angle is to be internal or external).

For a right hand corner position the mitre block to the right of the length of cornice.

All marks, measurements, and cuts must be made from the back of the cornice's wall edge.

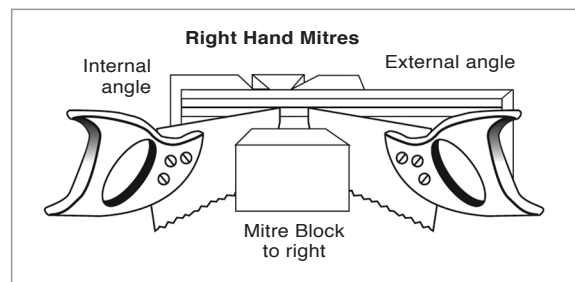
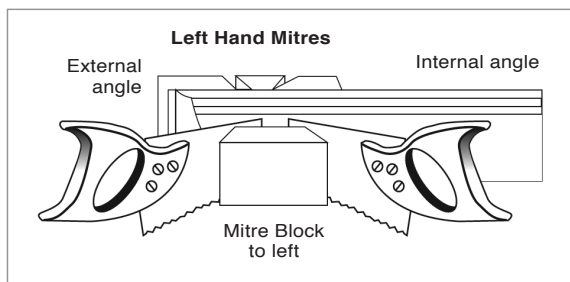

NUCORNICE INSTALLATION PROCEDURE

■ Easy to fit

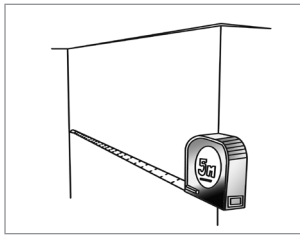

1. Measure

Measure length of cornice and angle

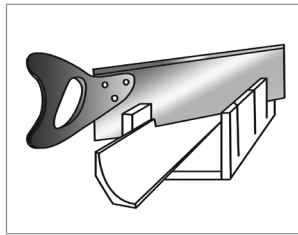

2. Cut

Use a mitre box and fine-tooth saw for cutting

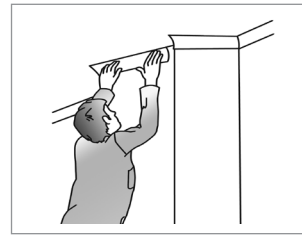

3. Fit

Installing the cornice. Refer Fig. 7

- Measure the length of Nucornice required and cut.
- Strike a chalk line on the wall to maintain alignment.
- Mitre the corners for a neat finish and nail to the brandering and to the wall or glue to ceiling board and to the wall.

Fig 7 : Section through edge of Ceiling showing installation of Nucornice

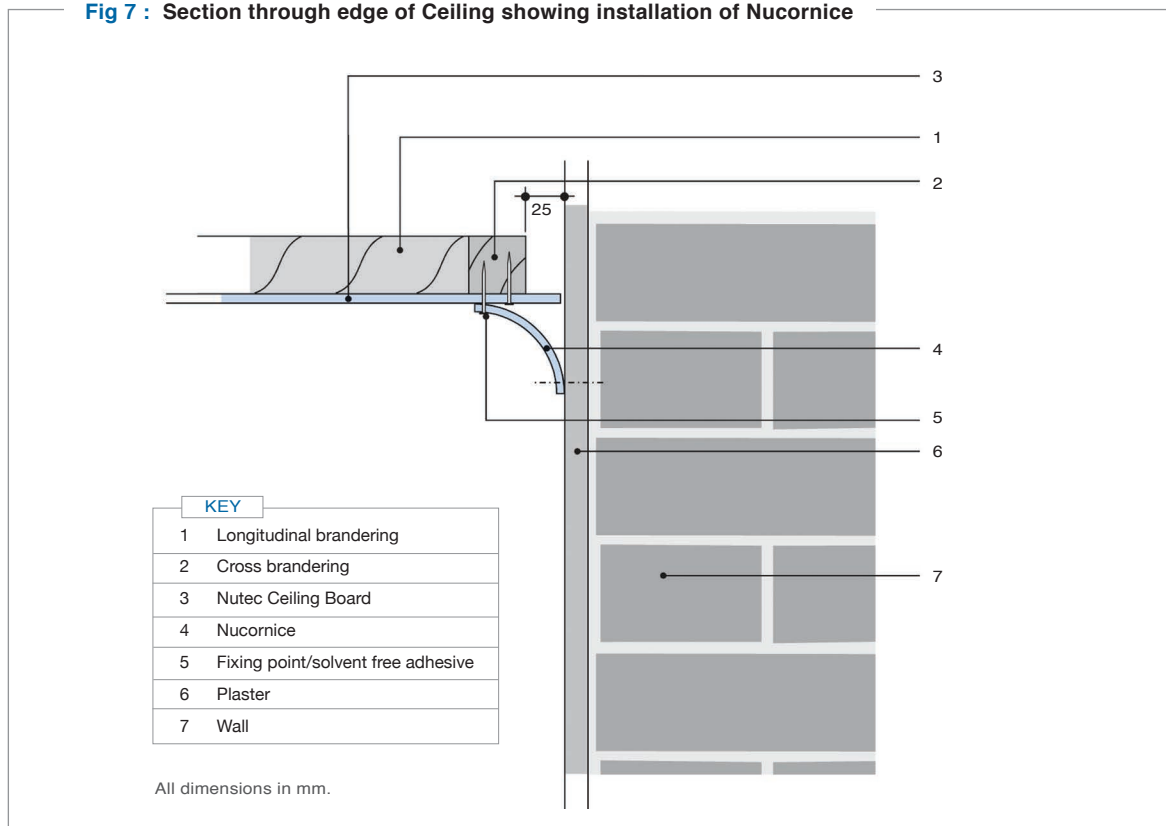

NUCORNICE ADHESIVE

Nucornice Adhesive

■ The Product

Nucornice Adhesive, an acrylic filler and adhesive, has been specifically developed for use with Nucornice and glues, seals and fills in one process.



■ Easy to Use

- Nucornice cornice are prepared the same way as conventional cornice.
- Cut Nucornice to size and apply Nucornice Adhesive evenly to the contact edges with a paint scraper. Ensure there is a 2 mm vertical gap between all sections of Nucornice to allow for movement.
- Press into position and leave. (Nucornice Adhesive bonds immediately)
- Remove excess Nucornice Adhesive with your finger, sealing the horizontal joints at the same time.
- Installed Nucornice must immediately be wiped clean of excess Nucornice adhesive with a damp cloth or sponge.
- Vertical joints and corners can be filled with Nucornice Adhesive about 7 days later, or just before painting.

■ Specifications

- Available ready-to-use in 310 ml tube and 2l and 5l re-sealable buckets.
- Fixes between 16 m and 20 m of 75 mm cove cornice per litre.
- Best applied with a paint scraper.

■ Benefits of Nucornice

- Nucornice is a fraction of the weight of conventional cornice.
- Nucornice does not suffer from breaking during transport and erecting.
- Nucornice Adhesive can be used against non-painted as well as painted walls.
- Gluing Nucornice prevents unsightly hammer marks and ugly nail heads, which need to be filled and sanded later.
- Gluing Nucornice seals the ceiling to the wall in one step and the bond is flexible enough to accommodate movement in ceiling and roof without cracking.
- Gluing Nucornice with Nucornice Adhesive cuts fixing and sealing time by up to half compared to the traditional nailing method of conventional cornice.

MECHANICAL AND PHYSICAL PROPERTIES

Mechanical and Physical Properties

- Mechanical and physical properties for plain and textured Nutec Ceiling Boards

Parameter	Unit	Nutec Board	Test Method
SPECIFICATIONS			
DIMENSIONS			
Thickness Tolerance:			
4 mm	mm	± 0.5	SANS 803
6 mm	mm	± 0.5	SANS 803
Length Tolerance:			
595 mm	mm	+0 or -1	SANS 803
1 195 mm	mm	+0 or -2	SANS 803
1 495 mm	mm	+0 or -5	SANS 803
1 800 mm to 2 400 mm	mm	+0 or -5	SANS 803
Width Tolerance:			
495	mm	mm± 2	SANS 803
595	mm	mm+0 or -2	SANS 803
Squareness			
All sizes	mm	Maximum 2	SANS 803
Edge Trueness:			
All sizes	mm	Maximum 3	SANS 803
PHYSICAL PROPERTIES			
Minimum MOR : With Grain	MPa	7.40 ⁽¹⁾	SANS 803
Minimum MOR : Across Grain	MPa	10.60 ⁽¹⁾	SANS 803
Target Density	g/m ³	1.26	ISO 8336
Maximum Hygral Linear Expansion	mm/m	2.47	SANS 803

(1) Dried till constant weight (2) Saturated with water (3) Equilibrium conditions

MECHANICAL AND PHYSICAL PROPERTIES

■ Mechanical and physical properties for plain and textured Nutec Ceiling Boards (*cont.*)

Parameter	Unit	Nutec Board	Test Method
TYPICAL VALUES			
Thermal Conductivity	W/m.K	0.19	ASTM C518
Thermal Expansion Coefficient			
20-70°C	°C-1	Negligible	SANS Doc. 722/W 1009
10-70°C	°C-1	9.31 x 10 ⁻⁶	ASTM C531
Moisture Movement			
With Grain	%	0.06	ASTM C1185
Across Grain	%	0.06	ASTM C1185
Moisture Content	%	6.25	ASTM C1185
Water Absorption	%	37.72	ASTM C1185
Permeability	-	No droplets formed	SANS 685 ASTM C1185 BS 4624
Water Vapour Transmission	ng/Pa.s.m ²	276.79	ASTM E96
pH	-	10 – 12	-
MECHANICAL PROPERTIES			
MOR : With Grain	MPa	4.20 ⁽²⁾	ASTM C1185
	MPa	7.50 ⁽³⁾	ASTM C1185
	MPa	11.20 ⁽³⁾	BS 4624
MOR : Across Grain	MPa	7.75 ⁽²⁾	ASTM C1185
	MPa	12.10 ⁽³⁾	ASTM C1185
	MPa	16.40 ⁽³⁾	BS 4624

(1) Dried till constant weight (2) Saturated with water (3) Equilibrium conditions

MECHANICAL AND PHYSICAL PROPERTIES

■ Mechanical and physical properties for plain and textured Nutec Ceiling Boards (cont.)

Parameter	Unit	Nutec Board	Test Method
Classification in Accordance to ASTM C1186	-	I	ASTM C1186
Compressive Strength Parallel to Surface of Board			
With Grain	MPa	10.86 ⁽²⁾	ASTM D1037
	MPa	15.57 ⁽³⁾	ASTM D1037
Across Grain	MPa	11.54 ⁽²⁾	ASTM D1037
	MPa	19.58 ⁽³⁾	ASTM D1037
Tensile Strength Parallel to Surface of Board			
With Grain	MPa	2.11 ⁽²⁾	ASTM D1037
	MPa	3.26 ⁽³⁾	ASTM D1037
Across Grain	MPa	2.24 ⁽²⁾	ASTM D1037
	MPa	2.88 ⁽³⁾	ASTM D1037
Tensile Strength Parallel to Surface of Board			
	MPa	0.83 ⁽²⁾	ASTM D1037
	MPa	1.02 ⁽³⁾	ASTM D1037
Young's Modulus (E.Mod)			
With Grain	MPa	5337 ⁽³⁾	ASTM C120
	MPa	3974 ⁽²⁾	ASTM C120
Across Grain	MPa	6474 ⁽³⁾	ASTM C120
	MPa	4681 ⁽²⁾	ASTM C120
Block Shear Strength			
	MPa	1.60 ⁽²⁾	ASTM D143
	MPa	1.32 ⁽³⁾	ASTM D143

(1) Dried till constant weight (2) Saturated with water (3) Equilibrium conditions

MECHANICAL AND PHYSICAL PROPERTIES

■ Mechanical and physical properties for plain and textured Nutec Ceiling Boards (cont.)

Parameter	Unit	Nutec Board	Test Method
FIRE PROPERTIES			
Surface Spread of Flame		Class 1	BS 476: Part 7 + SABS 10177: Part 111
Spread of Flame Index	-	Nil	SANS 10177 Part III
Heat Contribution Index	-	Nil	SANS 10177 Part III
Smoke Emission Index	-	Nil	SANS 10177 Part III
Surface Fire Index	-	Nil	SANS 10177 Part III
Surface Burning Characteristics			
FSI (Flame spread index)	-	0	ASTM E84
SD (Smoke developed index)	-	3	ASTM E 84
Non-Combustibility		Non-combus.	BS 476 Part 4, SANS 10177: Part V
Continuous Temperature	-	150°C	-
OTHER PROPERTIES			
Frost Resistance			
Cycles Completed	-	50	ASTM C1185
Strength Ratio	%	78,5	ASTM C1185
Biological Resistance			
Rodent Resistance		Class B1	SANS Method 5419
Termite Resistance		No Damage	SANS Method 5471
Resistance to Bacteria		No Growth	BS 5980

(1) Dried till constant weight (2) Saturated with water (3) Equilibrium conditions

CONTACT DETAILS

EVERITE NATIONAL OFFICE

Call Centre + 27 11 439 4400

www.everite.co.za



OTHER REGIONS

Sales Support Office

Telephone + 27 11 439 4400

Bloemfontein

Mobile 083 798 8049

Cape Town

Telephone + 27 21 981 5212

Durban

Telephone + 27 31 701 0959

East London

Mobile + 27 82 321 5451

Telephone +27 43 731 2367

George

Telephone + 27 44 873 2408

Mobile + 27 83 286 3435

Middelburg (Mpumalanga)

Mobile + 27 83 778 2787

Polokwane

Telephone + 27 15 297 3559

+ 27 15 297 3560/1

Port Elizabeth

Telephone + 27 41 451 0655

Mobile + 27 83 780 6162

Botswana (Gaborone)

Telephone + 27 11 439 4400

Namibia

Mobile + 264 81 124 2655

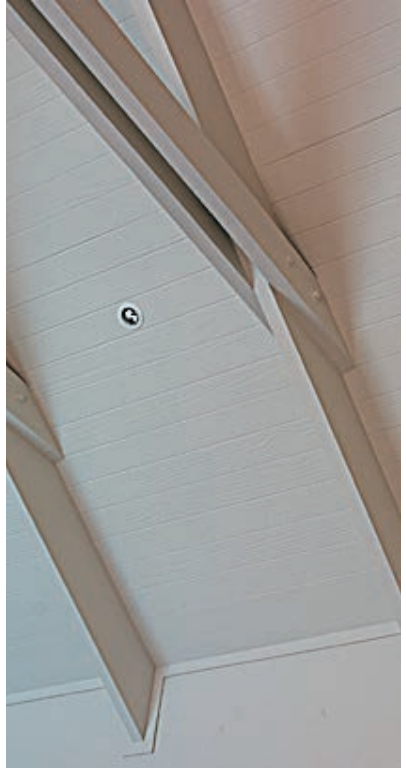



www.everite.co.za
call centre: +27 11 439 4400

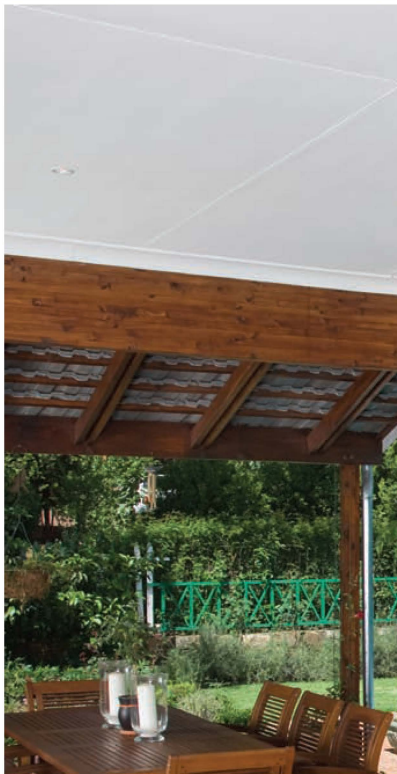

Copyright © 2012
Everite Building Products (Pty) Ltd.
All rights reserved.